

Sample/Pre-Board Paper 6
Class X Term 1 Exam Nov -Dec 2021
Science (086)

Time: 90 Minutes

General Instructions:

1. The question paper contains three sections.
2. Section A has 24 questions. Attempt any 20 questions.
3. Section B has 24 questions. Attempt any 20 questions.
4. Section C has 12 questions. Attempt any 10 questions.
5. All questions carry equal marks.
6. There is no negative marking.

Section A

Section – A consists of 24 questions. Attempt any 20 questions from this section.
The first attempted 20 questions would be evaluated.

1. A student added dilute HCl to a test tube containing zinc granules and made following observations :
 - (a) the zinc surface became dull and black
 - (b) a gas evolved which burnt with a pop sound
 - (c) the solution remained colourless
 - (d) the solution becomes green in colour
2. In an attempt to demonstrate electrical conductivity through an electrolyte, the following apparatus (figure) was set up.

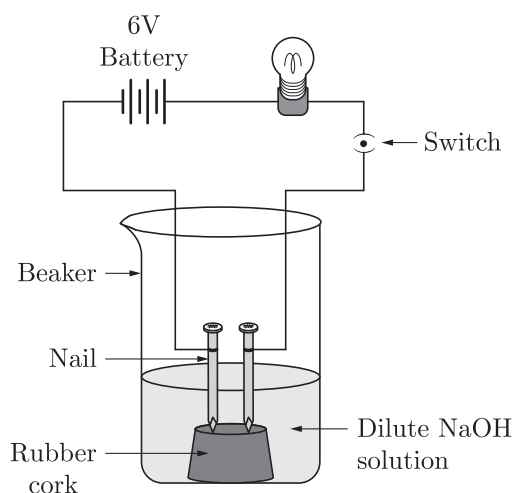

Which among the following statement (s) is (are) correct?

1. Bulb will not glow because electrolyte is not acidic.
2. Bulb will glow because NaOH is a strong base and furnishes ions for conduction.
3. Bulb will not glow because circuit is incomplete.
4. Bulb will not glow because it depends upon the type of electrolytic solution.

- (a) 1 and 3
- (b) 2 and 4
- (c) Only 2
- (d) Only 4

3. Which of the following statements are incorrect?
 1. Non-metals possess the property of ductility and malleability
 2. Non-metallic elements are brittle
 3. Metals can produce ringing sound by striking
 4. Melting points and boiling points of metals are low
 - (a) 1 and 2
 - (b) 1 and 3
 - (c) 1 and 4
 - (d) 2 and 3

4. Which of the following statements about a chemical reaction is true?
 - (a) The total mass is not altered.
 - (b) The total number of molecules remains unchanged
 - (c) The total number of moles remains the same
 - (c) The total number of reaction molecules is equal to the total number of molecules of the products formed

5. Which of the following are correctly matched?

1.	Acid + salt	metal + hydrogen
2.	Acid + metal carbonate	salt + carbon dioxide + water
3.	Metal oxide + acid	salt + water

- (a) 1 and 2
- (b) 2 and 3
- (c) 1 and 3
- (d) 1, 2 and 3



6. $\text{CuO} + \text{H}_2 \longrightarrow \text{Cu} + \text{H}_2\text{O}$
Which of the following pair is correct regarding to oxidation and reduction?

	Oxidation	Reduction
(a)	CuO	H_2
(b)	H_2	CuO
(c)	H_2O	H_2
(d)	H_2	H_2O

7. The following reaction is used for the preparation of oxygen gas in the laboratory

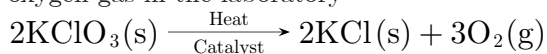

Which of the following statement(s) is(are) correct about the reaction?

- (a) It is a decomposition reaction and endothermic in nature.
(b) It is a combination reaction.
(c) It is a decomposition reaction and accompanied by release of heat.
(d) It is a photochemical decomposition reaction and exothermic in nature.

8. The schematic diagram is given below :

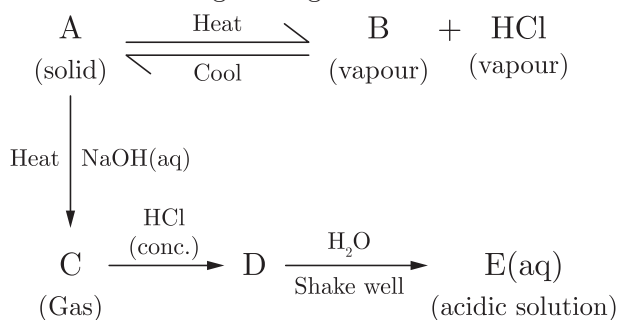

Which of the following is an incorrect statement?

- (a) *A* and *E* are chemically same.
(b) *A* and *D* are chemically same.
(c) *D* and *E* are chemically same.
(d) *C* and *E* are chemically same.
9. Which one of the following types of medicines is used for treating indigestion?
(a) Antibiotic
(b) Analgesic
(c) Antacid
(d) Antiseptic

10. When potassium iodine solution is added to a solution of lead nitrate reaction occurs.

- (a) combination
(b) decomposition
(c) displacement
(d) redox

11. The diagram shows part of the human gas exchange system.

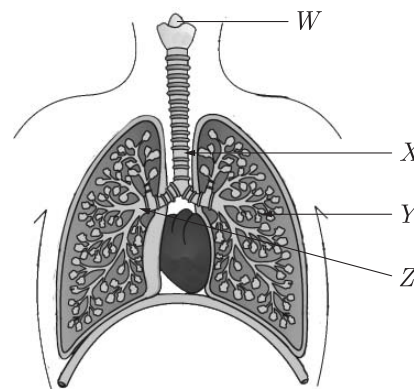

Here, *W*, *X*, *Y* and *Z* are?

	Bronchus	Bronchiole	Larynx	Trachea
(a)	<i>W</i>	<i>X</i>	<i>Z</i>	<i>Y</i>
(b)	<i>X</i>	<i>Z</i>	<i>Y</i>	<i>W</i>
(c)	<i>Y</i>	<i>W</i>	<i>X</i>	<i>Z</i>
(d)	<i>Z</i>	<i>Y</i>	<i>W</i>	<i>X</i>

12. The diagram shows the arrangement of cells inside the leaf of a green plant. (No cell contents are shown). Which of the following cells normally contain chloroplasts?

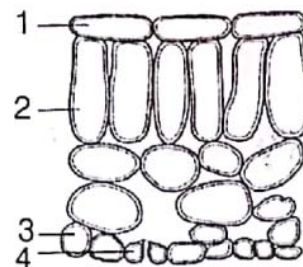

- (a) 2 and 4
(b) 2 and 3
(c) 1 and 2
(d) 1 and 4

13. The waste product from skin is known as?

- (a) Salts
(b) Urine
(c) Sweat
(d) Urea

14. The given figure represents the movement of water and minerals in xylem and movement of food in phloem.

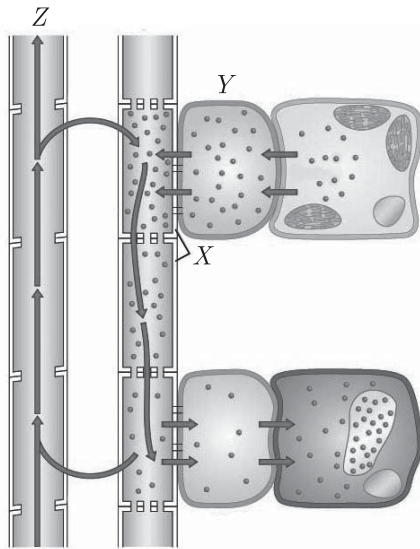

Choose the correct combination of plots provided in the following table:

	X	Y	Z
(a)	Major conducting cells in xylem	Denucleated	Flow is bidirectional
(b)	Major conducting cells in phloem	Nucleated	Flow is unidirectional
(c)	Major conducting cells in xylem and phloem	Denucleated	Flow is unidirectional
(d)	Cells of xylem but function is not defined	Nucleated	Flow is bidirectional

15. The given figure represents the structure of a nephron.

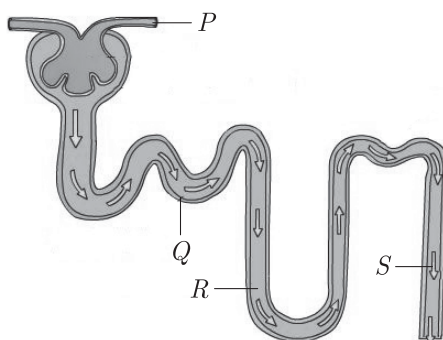

Which section of the nephron is responsible for concentrating the solute in the filtrate?

- (a) P
(b) Q
(c) R
(d) S

16. An experiment is set up as shown. Flasks 1 and 2 contain lime water. Air is pumped through the flasks.

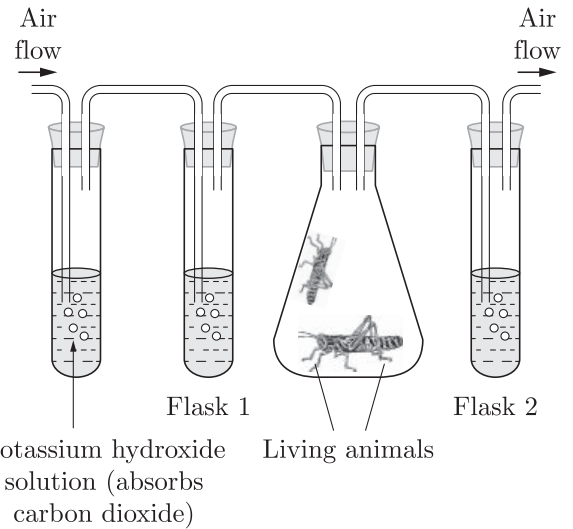

What is the appearance of lime water in flasks 1 and 2 after a period of ten minutes?

	Flask 1	Flask 2
(a)	Clear	Clear
(b)	Clear	White/Cloudy
(c)	White/Cloudy	Clear
(d)	White/Cloudy	White/Cloudy

17. While using an electric bulb, the reflection for street lighting should be from
(a) Concave mirror (b) Convex mirror
(c) Cylindrical mirror (d) Parabolic mirror

18. The path of a ray of light coming from air passing through a rectangular glass slab traced by four students are shown in figure. Which one of them is correct?

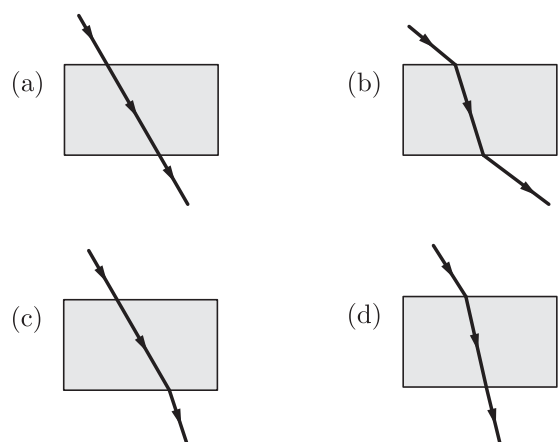

19. The image of the moon is formed by a concave mirror whose radius of curvature is 4.8 m at a time when distance from the moon is 2.4×10^8 m. If the diameter of the image is 2.2 cm, the diameter of the moon is-
(a) 1.1×10^6 m (b) 2.2×10^6 m
(c) 2.2×10^8 m (d) 2.2×10^{10} m

20. The focal length of a concave mirror is f and the distance of the object from the principal focus is a . The magnitude of magnification obtained will be
- (a) $(f + a)/f$ (b) f/a
(c) \sqrt{f}/\sqrt{a} (d) f^2/a^2
21. Choose the correct relation between u , v and R for spherical mirrors.
- (a) $R = \frac{2uv}{u+v}$ (b) $R = \frac{2}{u+v}$
(c) $R = \frac{2(u+v)}{uv}$ (d) None of these
22. A student determines the focal length of a device X , by focusing the image of a far off object on the screen positioned as shown in figure. The device X is a

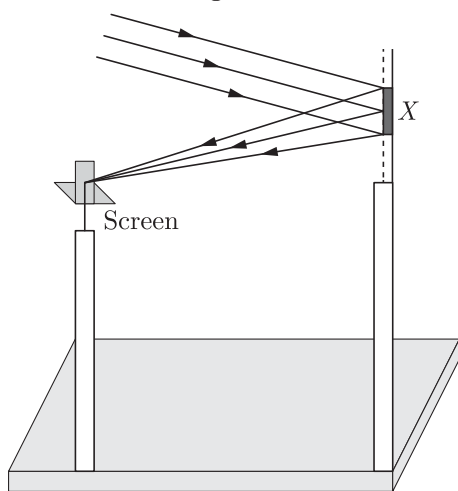

- (a) Convex lens (b) Concave lens
(c) Convex mirror (d) Concave mirror

23. Hold a concave mirror with its shining surface towards the sun. Take a sheet of paper and hold it in front of the mirror. Take the sheet of paper away from the mirror gradually till a sharp, bright spot appears on the paper. The sharp, bright spot is due to-
- (a) reflection of light (b) refraction of light
(c) scattering of light (d) diffraction of light
24. A prism ABC (with BC as base) is placed in different orientations. A narrow beam of white light is incident on the prism as shown in figure. In which of the following cases, after dispersion, the third colour from the top corresponds to the colour of the sky?

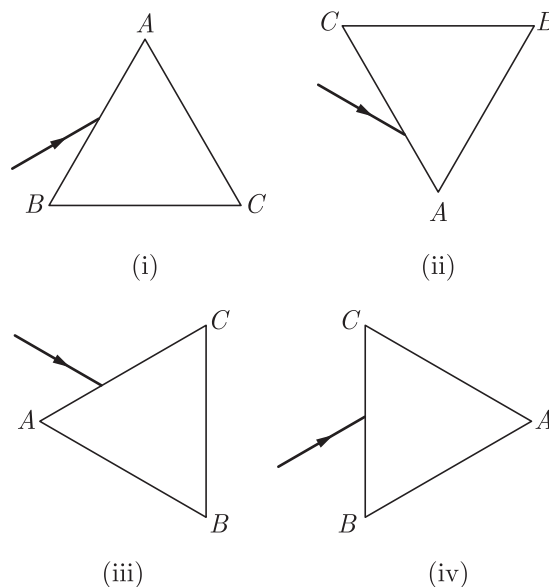

- (a) (i) (b) (ii)
(c) (iii) (d) (iv)

Section B

Section - B consists of 24 questions (Sl. No.25 to 48). Attempt any 20 questions from this section. The first attempted 20 questions would be evaluated.

25. A metal carbonate X on treatment with a mineral acid liberates a gas which when passed through an aqueous solution of a substance Y on reaction with the gas obtained at anode during electrolysis of brine gives a compound Z which can de-colourise coloured fabrics. The compounds X , Y and Z respectively are
- (a) CaCO_3 , $\text{Ca}(\text{OH})_2$, CaOCl_2
(b) $\text{Ca}(\text{OH})_2$, CaO , CaOCl_2
(c) CaCO_3 , CaOCl_2 , $\text{Ca}(\text{OH})_2$
(d) $\text{Ca}(\text{OH})_2$, CaCO_3 , CaOCl_2
26. Which of the following is true about the two statements?
- Statement I** : Reactivity of aluminium decreases when it is dipped in nitric acid
Statement II : A protective layer of aluminium nitrate is formed when aluminium is dipped in nitric acid.
- (a) I is correct but II is incorrect
(b) I is incorrect but II is correct
(c) Both the statements are correct and II is also the correct explanation of I
(d) Both the statements are correct but II is not correct explanation of I
27. Generally non-metals are not conductors of electricity. Which of the following is a good conductor of electricity?
- (a) Diamond
(b) Graphite
(c) Sulphur
(d) Fullerene

41. Four chambered heart is characteristics feature of
 (a) Fishes (b) Amphibians
 (c) Reptiles (d) Mammals
42. Oxygen is carried by the cells.
 (a) white blood cells (b) red blood cells
 (c) muscle cells (d) nerve cells
43. If the refractive index of a medium is 1.2, then light will pass through this medium with a velocity of
 (a) $2.5 \times 10^8 \text{ m} \cdot \text{s}^{-1}$ (b) $3 \times 10^8 \text{ m} \cdot \text{s}^{-1}$
 (c) $3.6 \times 10^8 \text{ m} \cdot \text{s}^{-1}$ (d) $4.8 \times 10^8 \text{ m} \cdot \text{s}^{-1}$
44. Which statement best describes the property of light waves illustrated in the diagram below?

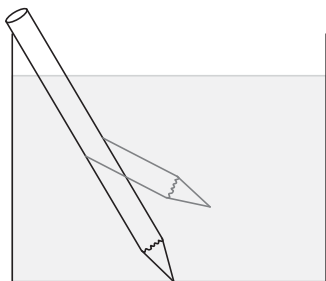

- (a) Some materials absorb light waves.
 (b) Some materials refracted by some materials.
 (c) Light waves are refracted by some materials.
 (d) Light waves are emitted by some materials.

45. What is the frequency of violet colour of wavelength 4000 \AA ?
 (a) $7.5 \times 10^{10} \text{ Hz}$ (b) $7.5 \times 10^{12} \text{ Hz}$
 (c) $7.5 \times 10^{14} \text{ Hz}$ (d) $3.75 \times 10^{16} \text{ Hz}$
46. Air is not visible because it
 (a) is nearly a perfectly transparent
 (b) neither absorbs nor reflects light
 (c) transmits whole of light
 (d) all of the above are correct
47. In vacuum the speed of light depends upon
 (a) Frequency
 (b) Wavelength
 (c) Velocity of the source of light
 (d) None of these

48. The composition of aqua regia is
 (a) Dil.HCl : Conc.HNO₃
 3 : 1
 (b) Conc.HCl : Dil.HNO₃
 3 : 1
 (c) Conc.HCl : Conc.HNO₃
 3 : 1
 (d) Dil.HCl : Dil.HNO₃
 3 : 1

Section C

Section- C consists of three Cases followed by questions. There are a total of 12 questions in this section. Attempt any 10 questions from this section.

The first attempted 10 questions would be evaluated

Case Based Questions: (49-52)

In chemistry a metal is an element that readily forms positive ions and has metallic bonds. A metal is a material that when freshly prepared, polished or fractured, shows a lustrous appearance and conducts electricity and heat relatively well. Metals are typically malleable or ductile.

The table shows the reaction of different metals with water.

Metal	Reaction with water	Reaction with steam
<i>P</i>	None	Mild
<i>Q</i>	Mild	Vigorous
<i>R</i>	Very slow	Vigorous
<i>S</i>	Vigorous	Violent

49. The current order of increasing reactivity of metals is:
 (a) $P < R < Q < S$ (b) $P < R < S < Q$
 (c) $P < Q < R < S$ (d) $S < Q < R < P$
50. Which metal is indicated by *R*?
 (a) Mg (b) Al
 (c) Fe (d) Cu
51. Which metal can displace *R* from its salt solution?
 (a) *P* (b) *Q*
 (c) *S* (d) Both (b) and (c)
52. Which metal is likely to be displaced by *R*?
 (a) *P* (b) *Q*
 (c) *R* (d) *S*

Case Based Questions: (53-56)

Digestion is a catabolic process in which complex and large components of food are broken down into their respective simpler and smaller forms with the help of various hydrolytic enzymes. In human beings, the process of intake of essential nutrients in the form of food takes place through an entire system in human includes alimentary canal and its associated digestive glands.

The alimentary canal is a muscular coiled tubular structure about 9 m in length that begins from mouth and ends with anus. The various organs of the human digestive system in sequence are: Mouth, Oesophagus (or Food pipe), Stomach, Small intestine and Large intestine. The glands which are associated with the human digestive system and form a part of the human digestive system are: Salivary glands, Liver and Pancreas. The ducts of various glands open into the alimentary canal and pour the secretions of the digestive juices into the alimentary canal.

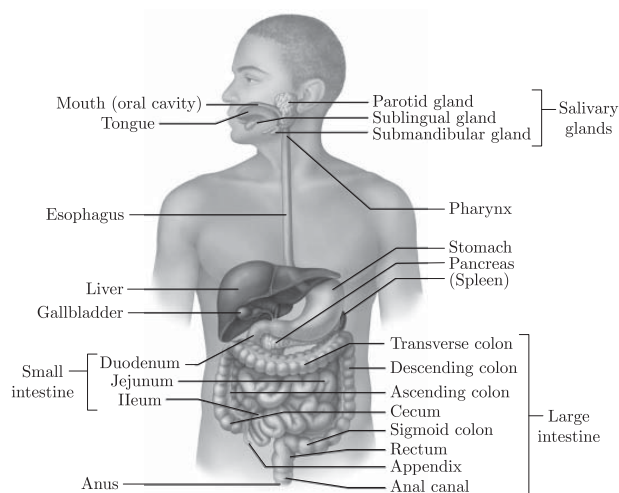

53. In which of the following organ is digested?
 (a) mouth
 (b) stomach only
 (c) large intestine
 (d) stomach and small intestine
54. Which of the following is the final product of digestion of protein?
 (a) Glycerol
 (b) Amino acids
 (c) Glucose
 (d) Nitric acid

55. What are peristaltic movements?
 (a) Rhythmic contraction of canal
 (b) Movement of heart
 (c) Movement of ribs
 (d) Movement of body parts
56. Which of the following enzyme is present in Saliva?
 (a) Amylase
 (b) Pepsinogen
 (c) Trypsin
 (d) Lipase

Case Based Questions: (57-60)

A student performs the experiment with a convex lens and he marked the table between image distance (v) and object distance (u).

	Object distance (u) (cm)	Image distance (v) (cm)
1	-90	+18
2	-60	+20
3	-30	+30
4	-20	+60
5	-18	+90
6	-10	+100

On the basis of the above table give the answer of following questions.

57. The focal length of the convex lens is:
 (a) -15
 (b) +25
 (c) -25
 (d) +15
58. In the table which observation is wrong?
 (a) S.No. 1
 (b) S.No. 4
 (c) S.No. 3
 (d) S.No. 6
59. If a convex lens is used to focus sunlight on a paper, where the paper should be placed so that it catches fire.
 (a) At 25 cm away from lens
 (b) At optical centre of lens
 (c) At principal focus.
 (d) At centre of curvature
60. The approximate value of magnification in case of S.No. 4 is
 (a) -1
 (b) -3
 (c) +4
 (d) +1

SAMPLE PAPER - 1 Answer Key

Paper Q. no.	Correct Option	Chapter no	Question Bank Q. no.
1	(b)	Ch-1	138
2	(c)	Ch-2	25
3	(c)	Ch-3	21
4	(a)	Ch-1	2
5	(b)	Ch-2	37
6	(b)	Ch-1	95
7	(a)	Ch-1	73
8	(b)	Ch-2	60
9	(c)	Ch-2	4
10	(c)	Ch-1	102
11	(d)	Ch-4	175
12	(a)	Ch-4	169
13	(c)	Ch-4	176
14	(b)	Ch-4	275
15	(c)	Ch-4	271
16	(b)	Ch-4	177
17	(b)	Ch-5	68
18	(b)	Ch-5	54
19	(b)	Ch-5	71
20	(b)	Ch-5	72
21	(a)	Ch-5	83
22	(d)	Ch-5	104
23	(a)	Ch-5	103
24	(b)	Ch-6	19
25	(a)	Ch-2	50
26	(c)	Ch-2	52
27	(b)	Ch-3	79
28	(a)	Ch-3	99
29	(b)	Ch-2	14
30	(d)	Ch-3	68
31	(a)	Ch-2	169

Paper Q. no.	Correct Option	Chapter no	Question Bank Q. no.
32	(c)	Ch-1	149
33	(a)	Ch-4	222
34	(a)	Ch-6	182
35	(b)	Ch-2	20
36	(c)	Ch-1	51
37	(c)	Ch-4	157
38	(c)	Ch-4	182
39	(c)	Ch-5	5
40	(a)	Ch-5	20
41	(d)	Ch-4	197
42	(b)	Ch-4	81
43	(a)	Ch-5	162
44	(c)	Ch-5	179
45	(c)	Ch-5	1
46	(d)	Ch-5	60
47	(d)	Ch-5	95
48	(c)	Ch-3	15
49	(a)	Ch-3	168
50	(a)	Ch-3	169
51	(d)	Ch-3	170
52	(a)	Ch-3	171
53	(d)	Ch-4	243
54	(b)	Ch-4	244
55	(a)	Ch-4	245
56	(a)	Ch-4	246
57	(d)	Ch-5	207
58	(d)	Ch-5	208
59	(c)	Ch-5	209
60	(b)	Ch-5	210